

Greenpower DEUTZ diesel engine

1500 RPM	Type GP 200DZ
----------	---------------

Engine: BF6M 1013 FCG3

These are the characteristics of the BF6M1013FCG3 Gen:

6-cylinders engine in V-configuration.

Turbocharging with intercooler air/air..

Cylinder displacement: 1,985 cm³.

4-valve technology.

“Split-pin” crankshaft.

Extremely compact design.

Acoustically optimized combustion system.

Rigid crankcase.

Global service network with over 3,000 service station in more than 150 countries.

Electronically controlled fuel injection pump with magnetic valve system type Deutz MVS (option).

Electronic engine governor type Deutz EMR 2.

These are the benefits for you:

- ▶ Its low noise radiation level is exemplary. Acoustically relevant components with a very rigid structure. This guarantees you a superior position to other competitors.
- ▶ The environmental friendly and high-tech combustion ensures not only excellent operating behaviour but also outstanding savings in economical costs.
- ▶ The control functions of the electronic engine governor make it possible to plan service intervals avoiding costly downtimes.
- ▶ The compact design saves installation space and thus installation costs.
- ▶ Low emission levels, the 1015 engine family meets TA-Luft standards both for NO_x 4000 mg/nm³ and NO_x 2000 mg/nm³

► Rating table: **BF6M1013FCG3** The Genset Engine **50Hz**

Engine type	BF6M 1013FCG3	
Speed	min ¹ rpm	1500
Frequency	Hz	50
Engine/genset ratings		
Continuous power, ICN (COP)	kW hp	166 222
Prime power, ICN (PRP) ³⁾	kW hp	183 245
Limited time running power, IFN (LTP)	kW hp	201 270
Typical generator power output		
Typical generator power output (COP)	kVA	168
Typical generator power output (PRP)	kVA	203
Typical generator power output (LTP)	kVA	204
Spec. fuel consumption PRP (LTP)		
100 % load	g/kWh lb/hp-hr	223 0,367
75 % load	g/kWh lb/hp-hr	222 0,365
50 % load	g/kWh lb/hp-hr	221 0,363

Standard specification

Standard engine: Connection housing SAE 2, with flywheel 10"/11.5

Cooling system: Cooling system HAT, depending on engine version incl. charge air cooler, pressure fan.

Exhaust system: Without silencer, with counterflange for exhaust system on the turbocharger.

Filter: Lube oil filter, air filter depending on engine version loose as kit or assembled.

Engine electrics: 12 Volt version, electrical engine governor standard in 6-cylinder FC engines.

Governor: Mechanical standard, optional electronic governor.

Miscellaneous: Painted dark gray.

Scope of Supply:

The engine and the alternator are mounted together forming a rigid monoblock, the shafts are connected by a flexible disc connection. The monoblock is mounted on a steel base frame via silent blocks. The base frame is including a fuel tank. Starting is electric and it includes a battery. The genset monitoring system consist of a control module.

PRP* Kva/KW:

Available electrical power (at a variable load) with a medium of 80% of the indicated maximum power. A 10% overload capability is available

LTP Kva/KW:**

Available electrical load (at a variable load) during a maximum of 500 hours per year. No overload capability is available.

CONTROL PANEL

Manual or automatic start control panel

Manual or automatic remote boot controller, selector switch for Off, Man and Auto with the key.

Complete motor protection functions with alarms visualized via LEDs in the front.

The control unit 6 is set via DIP switches in the rear part of the case.

Standard circuit breaker and differential relay.

TECHNICAL DATA

Engine		Alternator	
Engine type:	BF6M1013FCG3	Number of phase	3
Eng. Power kW COP:	86,1	No of pole	4
Eng. Power kW PRP:	183	Connection type	3-phase and 4 wires, "Y" type connecting
Eng. Power kW LTP:	201		
N° Cylinders:	6	Bearing Number	1
Displacement cm3:	7,1	Effect factor	0,8
Bore/stroke (mm/mm):	108/130	Protection class	IP23
Compression ratio:	18:1	Exciter Typ	Brushless, self-exciting
Cooling:	WATER	Alternator Capacity (kVA)	200
Injection:	DIRECT	Alternator Efficiencies (%)	93,7
Aspiration:	TURBO/INTERCOOLER	Air cooling Flow (m3/s)	0,514
Standard governor:	ELECTRONIC		
Governing control quality:	G3		
Speed droop mech gov. (%):	0-3		
Exhaust gases temperature (°C):	526		
Exhaust gases flow (m3/h):	1048		
Max Exh. Back pres. (mbar):	30		
Coolant capacity (lit.):	21		
Cooling air flow (m3/h):	11520		
Max allow. Intake dep. (mbar):	35		
Combustion air flow (m3/h):	453		
Oil cap. (Litres):	20		
Oil cons. (kg/hr or % of fuel cons):	0,06		
Min oil press warning (bar):	2,7		
Fuel cons. 25% lit/h:	13,1		
Fuel cons. 50% lit/h:	25,3		
Fuel cons. 75% lit/h:	37,7		
Fuel cons. 100% lit/h:	50,8		
Electric system VDC:	12V		
Type:	Neg to ground.		
Battery (Ah):	120		
Starting motor (kW):	3,1		
Flywheel Housing:	SAE2/10		

► Engine description

Type of cooling:	Liquid cooling, thermostatically controlled, charge-air-cooled engines with air-to-air charge air cooler
Crankcase:	High grey cast iron crankcase, for monobloc construction
Crankcase breather:	Closed-circuit crankcase breather
Cylinder head:	Grey cast iron block-type cylinder head
Valve arrangement/ timing:	One inlet and one exhaust valve per cylinder, actuated via tappets, push rods and rocker arms, camshaft driven by geartrain
Piston:	Three-ring piston, two compression rings and one oil scraper ring
Piston cooling:	Oil cooled with spray nozzles (channel-cooled piston)
Connecting rod:	Forged steel rod
Crankshaft bearings:	Tri-metal plain bearings
Crankshaft:	With integral counterweights
Camshaft:	Forged steel shaft
Lubrication system:	Forced-feed circulation lubrication with gear pump
Lube oil cooler:	Oil cooler integrated in coolant circuit
Lube oil filter:	Paper-type microfilter as replaceable-cartridge full flow filter
Injection pump/ governor:	Single injection pumps for each cylinder integrated in crankcase Mechanical centrifugal governor (standard); electronic governor (EMR) optional
Fuel lift pump:	Integrated in belt drive
Injection nozzle:	Six-hole nozzle
Fuel filter:	Replaceable cartridge
Alternator:	Three-phase alternator 12 V or 24 V
Starter motor:	12 V or 24 V
Heating system:	Optional connection for cab heating to engine cooling circuit

Identification of engine parts

Service side *BF6M1013FCG3*

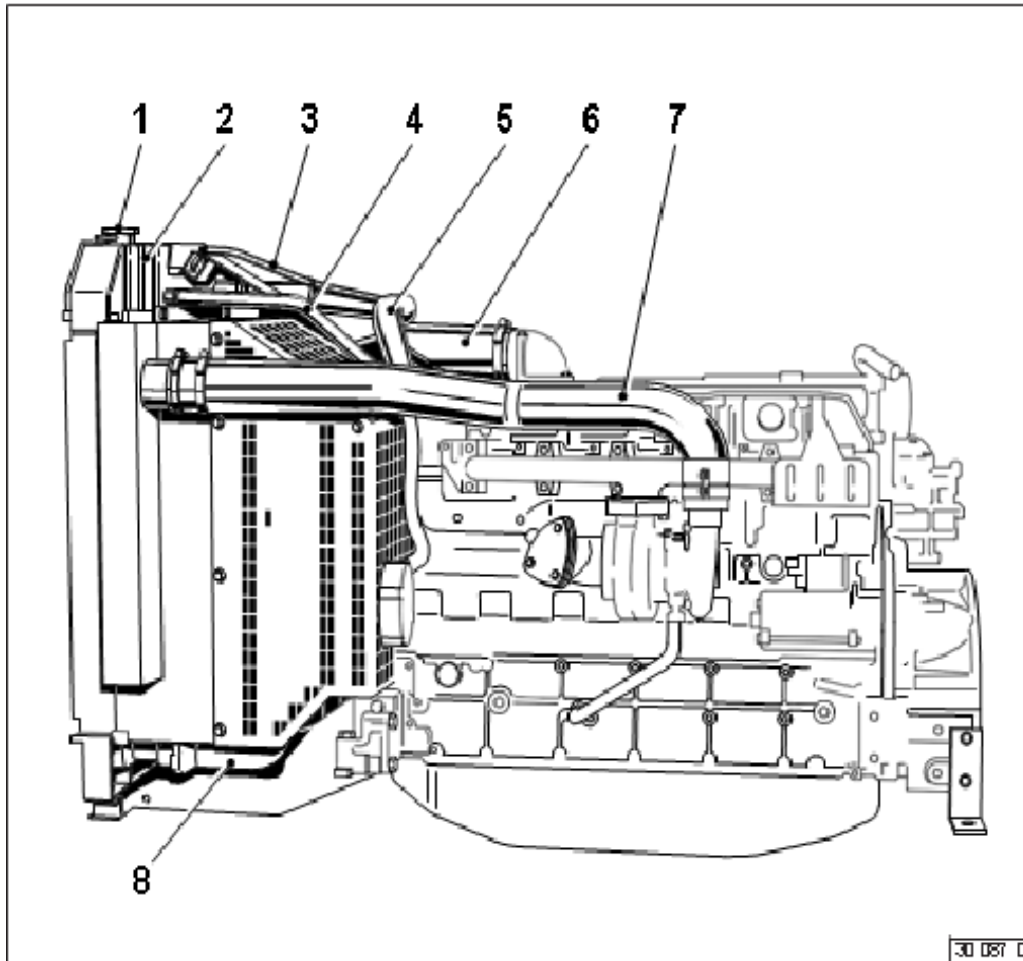

- 1 Filler neck with cap
- 2 The expansion tank
- 3 Vent line from the cylinder head to expansion tank
- 4 Expansion line from expansion tank to coolant pump
- 5 Coolant line from crankcase to engine fluid radiator
- 6 Charge-air line from the charge-air cooler to engine
- 7 Charge-air line from exhaust turbocharger to charge-air cooler
- 8 Coolant line from the engine fluid radiator to the engine thermostat

Identification of engine parts

Starter side *BF6M1013FCG3*

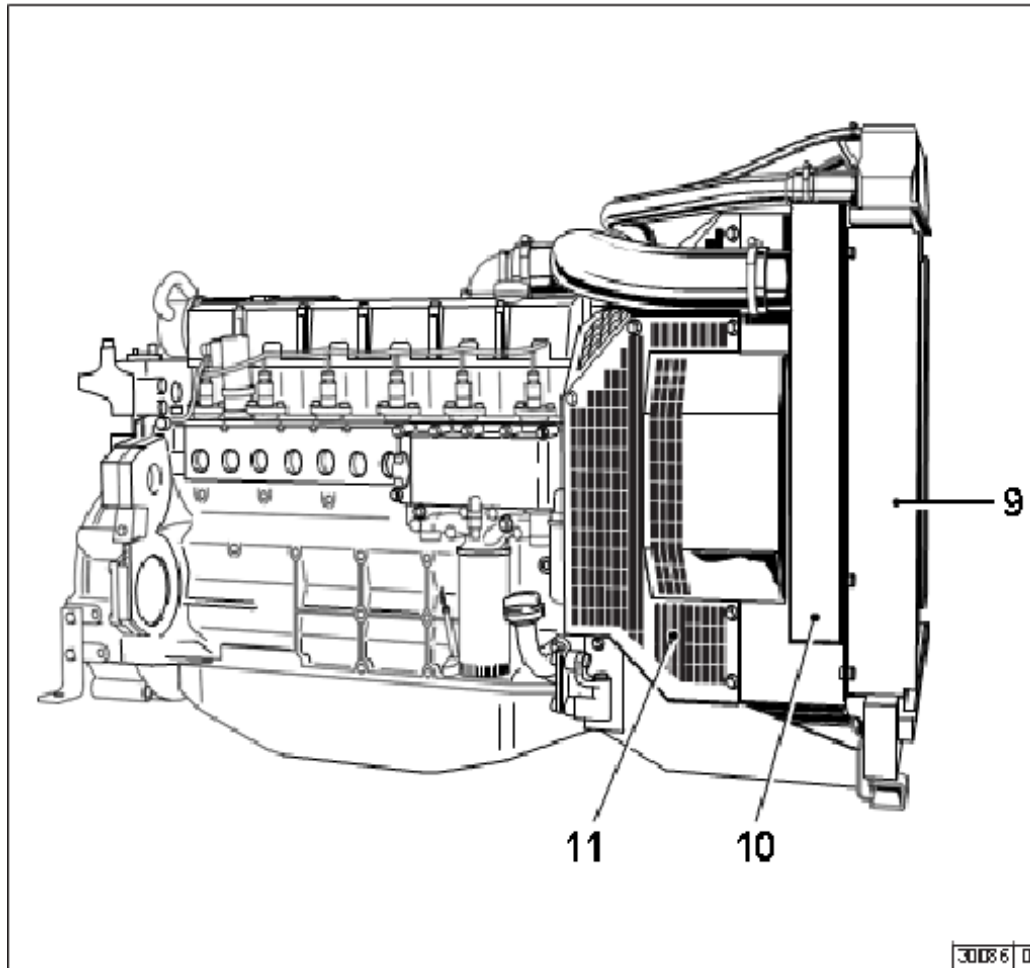

- 9 Engine radiator fluid
- 10 Charge-air cooler
- 11 Protective guard



Greenpower AB

Helsingborgsvägen Varalöv
262 96 Ängelholm, Sweden

Tel: +46 431-222 40

E-mail: info@greenpower.se

web: www.greenpower.se